Model : Finisher-F1 / Saddle Finisher-F2

Ref. No. : FF-T01-W-000118-01

Date : August 23, 2000

©Canon(UK)Limited

Location : PUNCHER UNIT

Subject : CORRECTING THE COMPOSITION OF THE PUNCHER UNIT (SERVICE PART)

Reason : A mistake has been discovered in the composition of the puncher unit available as a service part.

Details : The composition of the punch slide assembly indicated in the Parts Catalog (FY8-31EX-000; FIGURE Q13) includes "SUPPORT, SHAFT." However, the punch slide assembly does not include a shaft support, requiring a correction. (See the Attachment.)

FIGURE Q13 PUNCH SLIDE ASSEMBLY

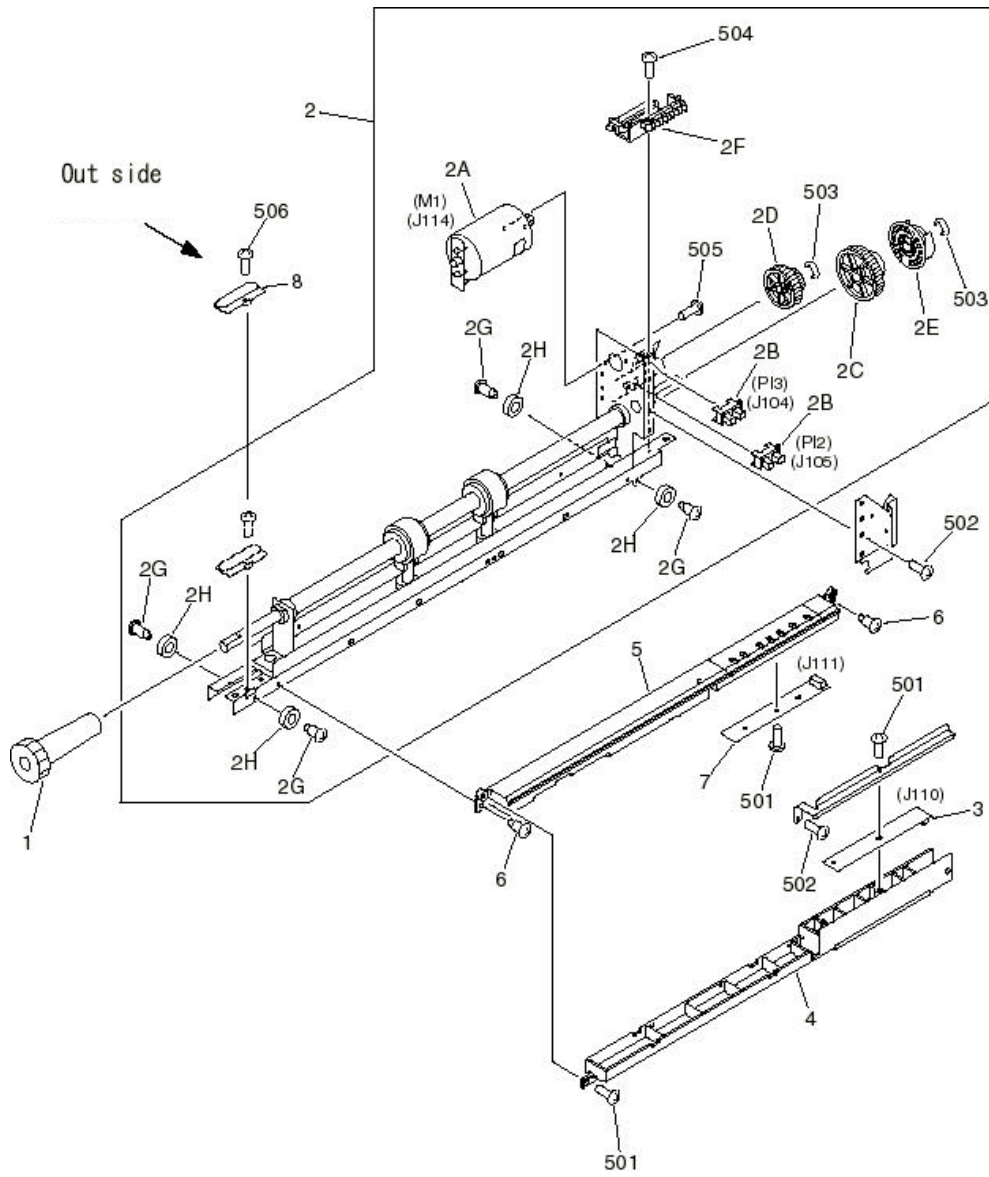

FIGURE & KEY No.	PART NUMBER	QTY	DESCRIPTION	SERIAL NUMBER / REMARKS
Q13 –	NPN	RF	ΠΥΝΧΗ ΣΛΙΔΕ ΑΣΣΕΜΒΛΨ	
1	FB4-6333-000	1	ΚΝΟΒ, ΠΥΝΧΗΡ	
2	FG6-6500-000	1	ΠΥΝΧΗ ΥΝΙΤ, 2 ΗΟΛΕ	PUNCHER UNIT-A1
	FG6-6501-000	1	ΠΥΝΧΗ ΥΝΙΤ, 3 ΗΟΛΕ	PUNCHER UNIT-B1
	FG6-6502-000	1	ΠΥΝΧΗ ΥΝΙΤ, 4 ΗΟΛΕ	PUNCHER UNIT-C1
	FG6-6503-000	1	ΠΥΝΧΗ ΥΝΙΤ, 4 ΗΟΛΕ	PUNCHER UNIT-D1
2A	FH6-1789-000	1	ΜΟΤΟΡ, ΔΧ 24ς	
2B	FH7-7462-000	2	ΠΗΟΤΟ-ΙΝΤΕΡΡΥΠΤΕΡ	M1J114
2C	FS7-0837-000	1	ΓΕΑΡ, 47Τ	PI3,2J104,105
2D	FS7-0838-000	1	ΓΕΑΡ, 19Τ/57Τ	
2E	FB5-6775-000	1	ΕΝΧΟΔΕΡ, Φ1350	
2F	FB5-5968-000	1	ΡΑΧΚ, ΣΛΙΔΕ	
2G	FS1-9102-000	4	ΣΧΡΕΩ,ΣΤΕΠΠΕΔ,Μ3	
2H	FS5-6528-000	4	ΡΟΛΛΕΡ	
2J	FB5-5969-000	1	ΣΥΠΠΟΡΤ, ΣΗΑΦΤ	
3	FG3-1310-000	1	ΠΗΟΤΟ ΤΡΑΝΣΙΣΤΟΡ ΠΧΒ ΑΣΣΕΜΒΛΨ	
4	FF6-0507-000	1	ΗΟΛΔΕΡ, ΣΕΝΣΟΡ, ΥΠΠΕΡ	J110
	FF6-0508-000	1	ΗΟΛΔΕΡ, ΣΕΝΣΟΡ, ΛΟΩΕΡ	
6	FS5-9687-000	2	ΣΧΡΕΩ, ΣΤΕΠΠΕΔ, Μ3	
7	FG3-1309-000	1	ΛΕΔ ΠΧΒ ΑΣΣΕΜΒΛΨ	
8	FB5-5969-000	1	SUPPORT, SHAFT	J111
501	XB4-7300-609	4	ΣΧΡΕΩ,ΤΑΠΠΗΝΓ,ΤΡΥΣΣ ΗΕΑΔ,Μ3Ξ6	
502	XB1-2300-609	5	ΣΧΡΕΩ,ΜΑΧΗ.,ΤΡΥΣΣ ΗΕΑΔ,Μ3Ξ6	
503	XD2-1100-502	2	ΡΙΝΓ,Ε	
504	XB2-4300-805	1	ΣΧΡΕΩ,Ω/ΩΑΣΗΕΡ,Μ3Ξ8	
505	XB1-1301-005	2	ΣΧΡΕΩ,ΜΑΧΗ.,ΠΑΝ ΗΕΑΔ,Μ3Ξ10	
	XB1-1301-005	5	ΣΧΡΕΩ,ΜΑΧΗ.,ΠΑΝ ΗΕΑΔ,Μ3Ξ10	PUNCHER UNIT-A1
	XB1-1301-005	4	ΣΧΡΕΩ,ΜΑΧΗ.,ΠΑΝ ΗΕΑΔ,Μ3Ξ10	PUNCHER UNIT-B1
506	XB1-2300-609	1	ΣΧΡΕΩ,ΜΑΧΗ.,ΤΡΥΣΣ ΗΕΑΔ,Μ3Ξ6	PUNCHER UNIT-C1/D1